

## EARLY ENTRY

These diamond blades are specifically designed for Early Entry machines. Supplied with 1/8" thick Stainless Steel Skid Plate, steel mounting pins that won't break, mounted with a locking pin to keep the plate in place. Skid Plate fits both Steel and Cast Skid Plate Saws.

No.	Diameter	Aggregate	Color Code
MS 6EE-P	6" x .095	Hard	Purple
MS 8EE-P	8" x .100	Hard	Purple
MS 10EE-P	10" x .110	Hard	Purple
MS 12EE-P	12" x .125	Hard	Purple
MS 6EE-R	6" x .095	Medium	Red
MS 10EE-R	10" x .110	Medium	Red
MS 6EE-G	6" x .095	Medium Hard	Green
MS 8EE-G	8" x .100	Medium Hard	Green
MS 10EE-G	10" x .110	Medium Hard	Green
MS 12EE-G	12" x .125	Medium Hard	Green
MS 13.5EE-G	13.5" x .125	Medium Hard	Green

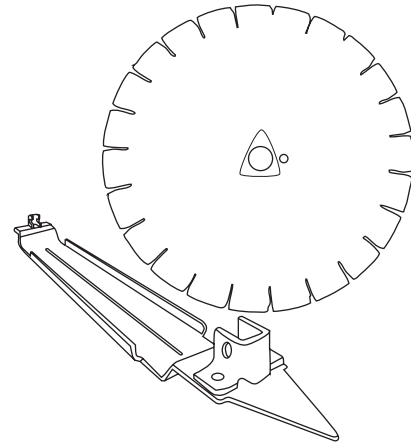

## WET CUT

Our wet cut blades are geared with the professional in mind. They are made with the finest industrial diamond. They can be ordered in diameters from 12" to 60". Blade thickness from .110 to .500. Our asphalt and concrete blades are leaders when it comes to cutting speed. We recommend that you talk with one of our diamond blade specialists when ordering professional wet blades.

### Recommended Equipment:

- Slab Saws 35HP & up \*
- Wall Saws
- Grooving Machines
- Stone & Refractory Saws

\* We recommend our Wet/Dry Segmented Blades for Low HP Saws (18 HP or less). See Dry Cut Segment.

**CALL FOR ASSISTANCE FROM OUR DIAMOND BLADE SPECIALIST FOR PRICING AND ORDERING.**

