

# DIAMOND BLADES

## CORE BITS

Masons core bits are the very best money can buy! Our bits are manufactured in the USA. We stock premium and heavy duty grade. But you have eight other grades to choose from. Diameter sizes range from 1/2" to 48" with a standard coring depth of 13". You can have any length of bit made on special order. All bits are laser welded at the diamond segment to ensure segment loss. Listed below are some features available.

<b>Turbo Segment</b>	Fast drilling - Long life
<b>Wide Spaced Segment</b>	Fast drilling - High production
<b>Thin Walled</b>	Fast drilling - Hand held drills
<b>Continuous Crown</b>	Chip free - Ceramic tile, Granite & Marble Prestressed cable, Loose rebar
<b>Dry Cut Bit</b>	Soft brick/block applications
<b>Open Back Bit</b>	Easier bit retrieve when hung up
<b>Threaded Bit Barrels</b>	Good for deep drilling
<b>Diamond-Carbide Duct Bits</b>	Drills concrete down to metal duct Flip lever carbide teeth engage to drill out metal duct raceway

*We suggest you call and talk with our Diamond Equipment Specialist so we can recommend the right bit for you.*

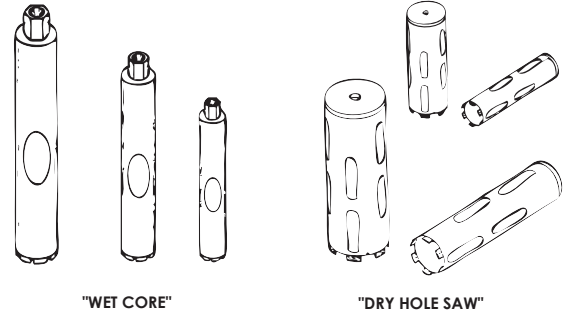

## DIAMOND DISC PADS (HOOK-AND-LOOP)

Diamond Disc Pads deliver cutting-edge finishing and grinding. It's the perfect product for concrete grinding, sanding and buffing applications. Attaches discs securely to your tools and allows fast and easy replacement.

No.	Grit	Size	Color	Type	Wt (lbs)
TAB DP125	120	4" x 1" open	black	flexible	0.40
TAB DP74	220	4" x 1" open	red	flexible	0.40
TAB DP40	320	4" x 1" open	yellow	flexible	0.40
Disc Pad Holder					
TAB DP4	---	4" x 5/8" - 11	center water feed		0.40

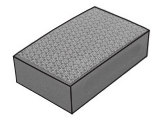

## DIAMOND HAND PADS

Color-coded hand pads combine the durability and aggressiveness of diamond in a high strength, flexible backing. Shaping rapid stock removal, torch-up and repair on concrete ceramics, stone, marble, glass, composites and hand materials.

No.	Size	Grit	Color	Wt (lbs)
TAB HP125	2 1/4" x 3 3/4"	120	Black	0.73
TAB HP74	2 1/4" x 3 3/4"	220	Red	0.73
TAB HP40	2 1/4" x 3 3/4"	320	Yellow	0.73

## PAINT REMOVAL CUP WHEEL

Poly Crystalline Diamond Cup Wheel specifically designed to remove epoxy paint, and elastomeric coatings. 5/8"-11 threaded hub. **Should not be used for grinding.**

No.	Size	Wt (lbs)
DP 4.5PCD	4 1/2" x 5/8"-11	1.50
DP 7PCD	7" x 5/8"-11	2.00



## GRINDING WHEELS

High Speed Dry Turbo & Segmented Grinding Wheels come in three types, Turbo, Single Row and Double Row. Also 3 Grits: (aggressive), Medium (Smoothing) and Fine (Polishing). Arbors may be ordered without nut. They are substituted with 7/8" hole with 5/8" insert.

No.	Diameter	Arbor	Grit/Style	Color	Wt (lbs)
DO 4PWCH	4"	5/8"-11	Coarse/Turbo	Gold	1.00
DO 4PWFN	4"	5/8"-11	Fine	Gold	1.00
PA 4PWCH	4"	5/8"-11	Coarse/Turbo	Green	1.00
DO 5PWCH	5"	5/8"-11	Coarse/Turbo	Gold	1.50
DP 4HDBLCUP	4"	5/8"-11	Medium/Dbl Row	Blue	1.00
DP 7HDBLCUP	7"	5/8"-11	Medium/Dbl Row	Blue	2.00
DO 7PWCH	7"	5/8"-11	Coarse/Turbo	Gold	2.00
Economy					
DP 4.5DBLSBCUP	4.5"	5/8"-11	Dbl Row	Blue	1.25
DP 7DBLSBCUP	7"	5/8"-11	Dbl Row	Blue	2.00

