

REBAR BENDER

This rebar bender is a portable machine designed for accurate, precise bending. Each bend is automatically made to the exact angle desired. Bends a full range of bar sizes up to 7/8" diameter (#7 rebar). A foot switch is included for hands-free bending. This bender features single phase, 115 volt universal motor, is compact and lightweight for easy portability and extremely easy to operate. Single control knob selects precise bending angle from 0° to 180°. Electro magnetic clutch is close-coupled to the motor; motor runs only during bending operation for lower noise level and energy efficiency. Sealed clutch-gear case prevents contamination and requires no inspection or maintenance. Emergency stop button and flush mounted start button for safety. Tool kit included. Other sizes available.

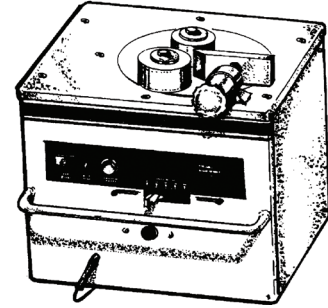

No.	Size of rebar	Wt (lbs)
BN DBD25X	#7	200.00

HYDRAULIC REBAR CUTTER

Electric-Hydraulic rebar cutter simplify the job. They are compact, portable machines than can easily and safely cut rebar right at the job site with minimum effort. Our lightweight, hand held cutters can be used on virtually any rebar job - from slabs and masonry walls to large scale buildings and bridges. With weights from 10.50 lbs. to 38.00 lbs., they are easily carried on the job and can be used overhead.

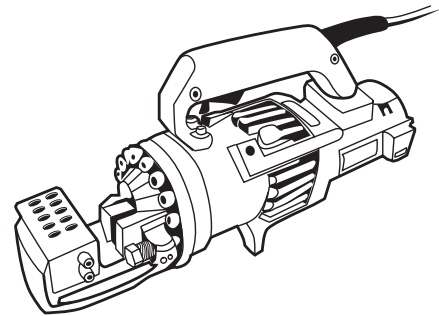

No.	Max Size of rebar	Voltage	AMPS	Wt (lbs)
BN DC20WH	#6 Bar	115V 50/60Hz	10.0	25.4

No.	Replacement Jaw	Cutter
BN 20XHJAW		BN DC20WH