

PROPANE BURNER

LP GAS

Puts instant heat where you want it. Perfect for melting ice build up, thawing pipes in frozen ground and heating work areas. Ground maintenance crews use for burning weeds, stumps, and grass between paving bricks. Each burner comes with a crass needle valve, ten feet of hose, and a fitting with built in excess flow valve to shut off gas if the flame goes out or the hose is cut. Propane tank not included.



ME WB

No.	Description	Wt (lbs)
ME WB	Weed Burner Assembly	5.00

PUMPS

HAND PUMP

The inexpensive GP-2 heavy duty is the ideal tool for placing grout anywhere that high pressure is not required. Pumps most types of prepackaged non-shrink cement g Hand operated, no electric or air power source required. Output capacity is 6 gallon minute at 15psi. Hopper size is .62 cu. ft., vertical lift. Capacity is 12 ft. standard hose ID x 60" clear vinyl.

No.	Description	Wt (lbs)
AP GP2HD	Pump	21.00
AP 5019-20	Repair Kit	0.20

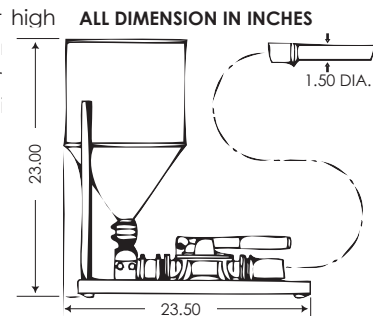

AIR GROUT PUMP

This unique portable piston pump is specifically designed for pumping of high viscosity slurries and grouts. The CG-050 is the only small, lightweight pump available that efficiently transfers cement slurries and premixed grout. And, it delivers at rates up to 5 gpm with pressures to 225 psi. It's engineered for minimal maintenance. The pump has just three wetted and only five working parts. Quick disconnect couplings allow rapid disassembly in less than 30 seconds. It's easy to clean and maintain in the shop or field. Safe, compressed air drive is especially suited for mines, tunnels, remote sites where electricity is unavailable and confined spaces where fuel fumes are dangerous. One man operation saves time and money. Drive power is 100 psi, 15 cfm air. Standard with heavy duty 1" ID x 12½ lf hose with quick lock couplings. 25 or 50 lf heavy duty hose available.

No.	Size	Wt (lbs)
CG 050	44" long x 10" wide x 21" high	52.0

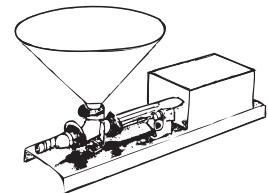

AIR GROUT PUMP & MIXER

Described above. Together, they deliver low viscosity cement, sand/cement and premixed grout rates up to 5 gpm with pressures to 225 psi. The large 34 gallon mixing tank has specially designed blades and baffles that develop high shearing action. The action provides complete wetting and produce superior mix instantly. The mix is then transferred into the holding hopper. The entire system is balar to allow continuous feed and uninterrupted production. It's complete, ready for fast mobilization can be transported in a pickup truck. It's also easy to operate. One operator controls the mixer, p and productivity. Drive power is 100 psi, 85 cfm air. Standard with heavy duty 1" ID x 12½ lf hose with quick lock couplings. 25 or 50 lf heavy duty hose available.

No.	Size	Wt (lbs)
CG 550P	44" long x 27" wide x 48" high	275.0

